

Mech-Elec[®]



Smoke Control Damper

SC Series

Elevated Temperature
Smoke Control Damper

SC Series

elevated temperature smoke control

Mech-Elec®

Introduction

The SC Series Smoke/Control Damper has been designed for installation primarily into Fire-Rated Ventilation Ducts to control low-medium air velocities.

Its all steel construction is robust, with detail to its application, performance and size as required by specifiers and contractors.

Its design, construction and material selection have been specific so as to ensure a high quality, low-maintenance product is manufactured, supplied and installed.

Single section units are available from 100mm² to 1200mm².

Specifications and Testing

- Unless stated otherwise, flange models are suitable for classes A & B of DW144, with spigot models suitable for classes A, B & C of DW144
- Conformance to DW144 and Eurovent 2/2 classes A - C, as relevant
- Blade construction has been fire tested to BS476 part 20, 1987 for integrity and leakage
- Elevated temperature tests, reports 231297, 234486 and 27438 refer
- Resistance tested by BSRIA, report 15633/1 refers
- Leakage tested by BSRIA, report 15633/1 refers
- 28 day salt corrosion tested. Chatfield report RLR3 refers

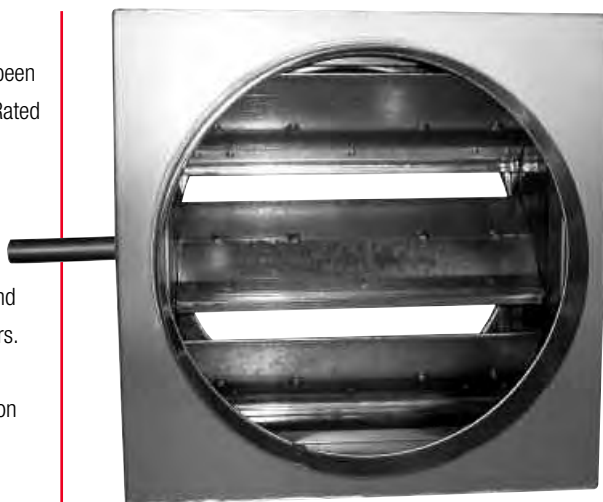

Features

- Standard blade and case construction is galvanised mild steel, with grade 302S stainless steel side seals
- Unique one-piece double-skin interlocking airfoil blades
- Four casing options
- Linkage out of airflow
- Optional blades and case in grades 316 or 430 stainless steel
- Grade 316 stainless steel side seals available to order
- Infinite sizing capability from 100mm square to 1200mm square
- Variable flange dimensions and casing widths

Blades

The 100mm wide steel airfoil inter-locking blades are fitted to 19mm diameter spindles for robust, low-friction rotation.

Galvanised blades are offered as standard, with Stainless Steel Grade 430 and 316 options available to order. Where stainless steel blade option is requested, Grade 430 will be supplied unless otherwise stated.

Fitted as standard, is grade 302S stainless steel blade end-seals.

Opposed blade operation only.

Special Note: For applications which necessitate the blades to be installed vertically, BSB's Sales Office must be informed so that thrust bearings are fitted to eliminate blade friction.

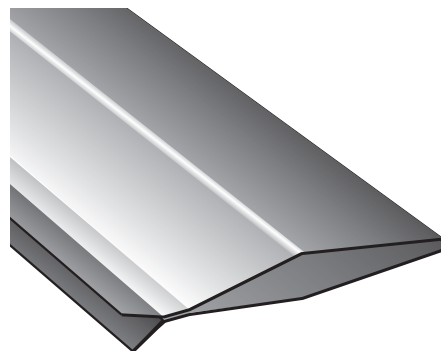

SC Series

dimensions



Where damper heights are requested in 100mm increments, the damper air way size will be 12mm greater with top and bottom flanges amended to accommodate the blade profile, with the overall flange size being unaffected.

Model SC Flangefit

Width x Height = 100mm to 1200mm

Standard Dimensions

A = 160mm as standard. 140mm and 200mm available to order.

B = 40mm as standard. 30mm, 35mm and 50mm available as detailed below:

Flange Size	Case Width
30mm	160mm or 200mm
35mm	160mm or 200mm
40mm	all width variants
50mm	all width variants

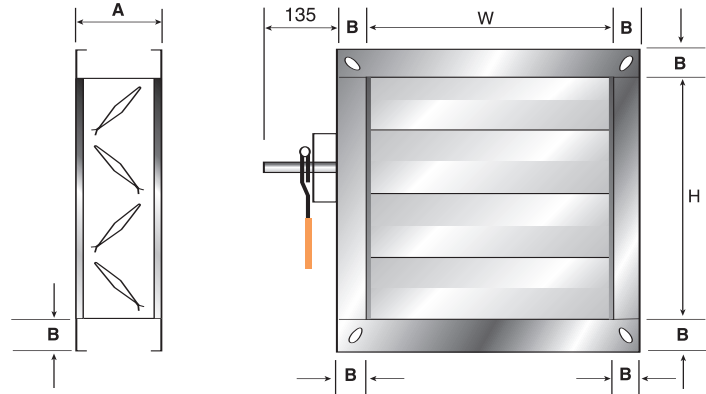

Model SC Spigotfit

Width x Height = 100mm to 1200mm

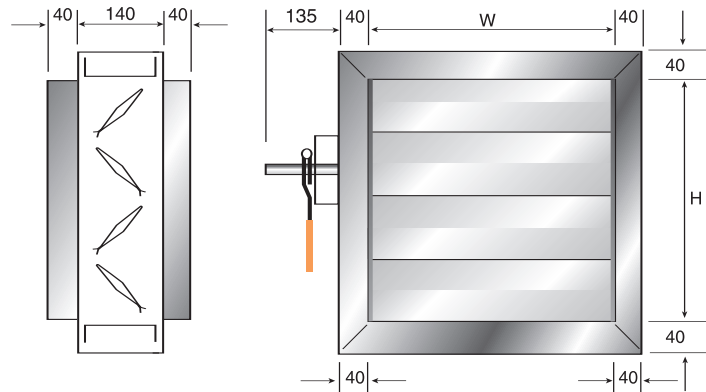

Model SC Circular

Width x Height = 100mm to 1200mm

* = 40mm (100 – 354mm diameter)
55mm (355 – 1200mm diameter)

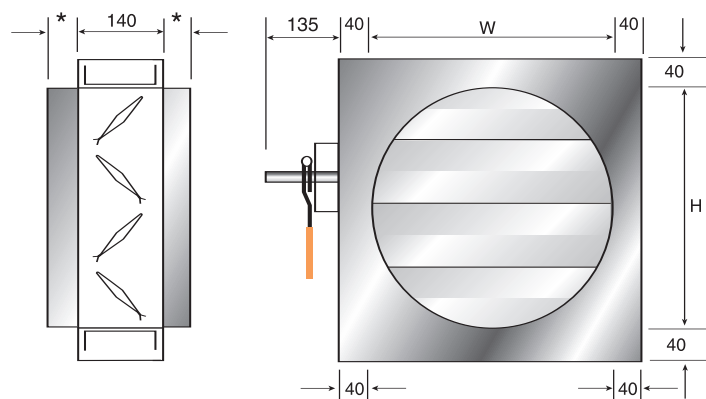

Model SC Flat Oval

Width x Height = 100mm to 1200mm

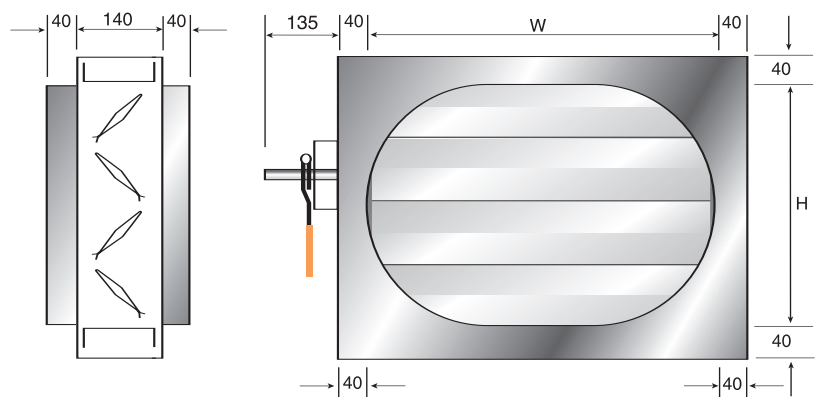

Elevated Temperature Test applied to a manually operated damper

A damper was placed into a furnace at ambient temperature (22°C), the furnace was ignited with the temperature being raised uniformly to 480°C and held for 30 minutes. The temperature was then raised to 700°C and held for a further 90 minutes. The temperature was then finally raised to 800°C for a further 120 minutes.

The damper was then removed and whilst still "cherry red" was inspected and operated. The blades and linkage rotated freely with all rivets, welds and components remaining intact.

The scope of the test was to test the damper's operation at an elevated temperature, in addition to establishing its integrity and distortion.

The conclusion of this test is that the design, construction and engineering tolerances permitted this product to be tested and operated at an "elevated temperature" successfully.

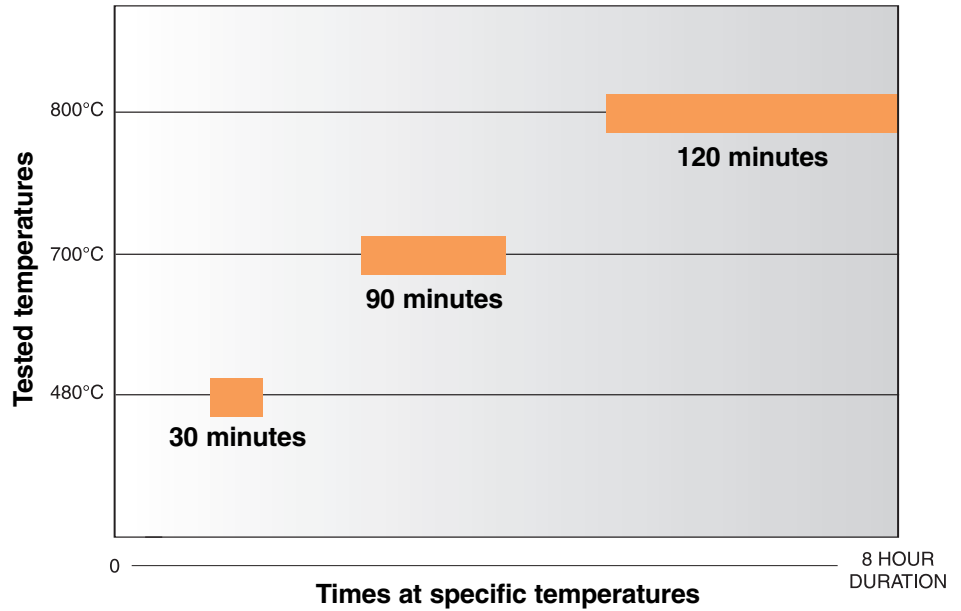

Special Note: When motors and/or other ancillaries are used in elevated temperatures, please consult with the manufacturers for suitability to the application.

BSB have concluded other tests at specific temperatures in addition to this test, all with satisfactory results.

Weight Chart (Kg) Flanged Model

Damper Height (mm)	Damper Width (mm)											
	100	200	300	400	500	600	700	800	900	1000	1100	1200
100	4	4	5	6	6	8	8	9	10	10	12	13
200	5	6	7	8	9	10	11	12	13	14	15	16
300	6	8	9	10	11	13	14	15	16	17	18	19
400	8	9	10	11	13	14	15	16	18	19	20	21
500	10	11	13	14	15	16	18	19	21	23	24	25
600	12	13	14	16	18	19	21	23	25	27	28	29
700	14	15	16	18	19	21	23	25	27	29	31	32
800	15	16	18	19	21	23	25	27	29	31	33	35
900	16	18	19	21	24	26	28	30	32	34	36	38
1000	17	19	21	23	26	28	30	32	34	36	39	41
1100	18	21	23	25	28	30	33	35	37	40	43	45
1200	20	22	25	28	30	33	35	38	40	43	45	48

Please note that these values have been rounded up or down to whole values and are therefore illustrated for estimation purposes only.

Pressure Drop BSRIA Report 15633/1

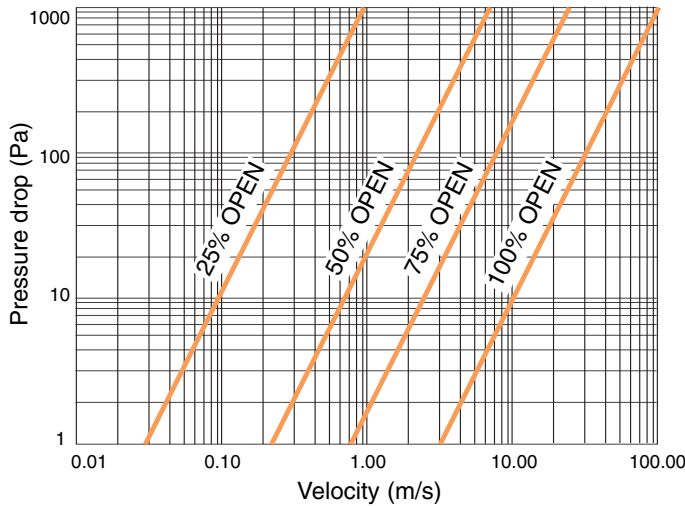

Calculated performance at various damper settings.
Individual data sheets are available for each blade setting.

Leakage BSRIA Report 15633/1

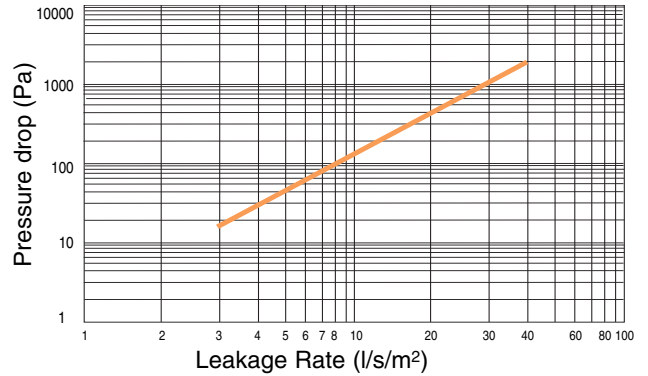

Static Pressure Pascals	Leakage per m ² l/s/m ²	Leakage l/s
15.6	2.970	0.891
29.4	4.239	1.272
74.8	7.035	2.111
162.2	10.636	3.191
225.4	12.604	3.781
380.0	16.230	4.869
660.0	21.583	6.475
955.0	25.511	7.653
2020.0	40.428	12.128

Permitted Case Leakage at Various Pressures

The Graph from HVCA's Publication DW144 illustrates the Flange Models Casing Leakage to Classes A & B.

For conformance to Class C Leakage, the fully welded Spigot Model should be supplied.

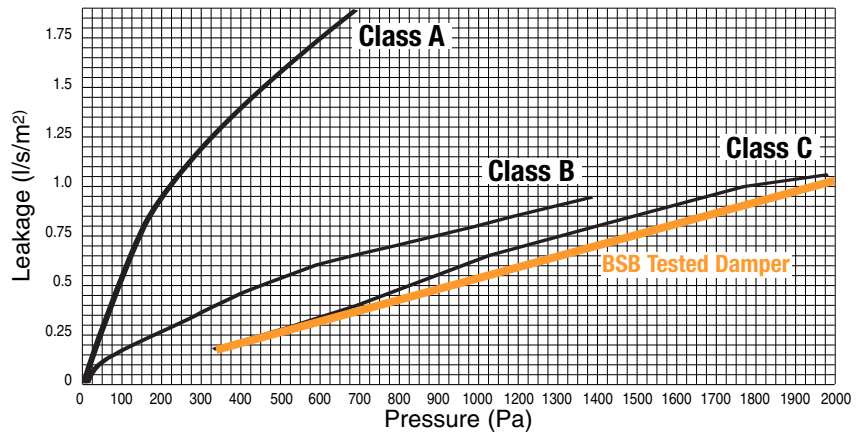

Torque Chart (Nm)

Duct Pressure (Pa)	Damper Size (Width x Height in mm)		
	200 x 200	600 x 600	1200 x 1200
250	3	7	12
500	4	8	13
750	5	9	14
1000	6	10	15

Please note that these values have been rounded up or down at blade inter-action, with actual blade rotation being at reduced torque levels.

SC Series

product specification and multiple assemblies

Mech-Elec®

Product Specification

Case

Material is 1.2mm galvanised coated mild steel to BS EN 10142 1991, coating class FE P02b Z275 Na.

Spindle covers are of "Top Hat" design to allow the use of clamps onto the flanges.

Blades

Nominal 100mm wide one-piece double skin airfoil interlocking blades.

Material is 0.7mm galvanised coated mild steel to BS EN 10142 1991, coating class FE P02b Z275 Na.

Stainless steel blades (0.7mm) to grades 430 or 316 to BS 1449 Part2 1983 S172B are available.

Blade Spindles

Manufactured from 19mm steel tube, extending the full length of blade into and through the "blow through" bushes.

Material is 1.2mm galvanised coated mild steel to BS EN 10142 1991, coating class FE P02b Z275 Na.

Optional is grade 316-S11 to BS 1449 Part 2 1983 S172B.

Blade End-Seals

Manufactured from grade 302S stainless steel to BS 5770 Part 4 1981. Radius profile 170mm.

Linkage

Operation via drive bars 3.2mm x 20mm in size, manufactured from bright mild steel to BS EN 10142 1991. drive bars are positioned out of airflow, connected to blade spindles via crank arms.

Opposed blade operation is standard.

Installed on both sides of the flange case are cover plates to protect the linkage from dust or damage, in addition to minimising casing leakage to requirements of DW144 as standard.

Bushes

Standard are "blow-through" bushes pre-formed into the galvanised steel flange casing, allowing the spindles to rotate freely.

Size Range

100mm x 100mm to 1200mm x 1200mm as a single section.

Damper Operating Temperature Range

BSB has tested the SC Series Smoke Control Damper at elevated temperatures for 8 hours. Our test reports 231297,234486 and 27438 refer.

Test Specification

Conformance to DW144 as relevant. Salt corrosion tested for 28 days.

Resistance Test

Tested by BSRIA, report 15633/1 refers.

Leakage Test

Tested by BSRIA, report 15633/1 refers.

(See Page 5 for illustrations)

Multiple Assemblies

Illustrated opposite are several variants to multiple section units. Where sizes exceed 1200mm x 1200mm square, multi-section units will be supplied.

When there are transportation restrictions, large multiple units will be broken down and shipped as individual sections for site assembly. Unless requested, joining strips would not normally be supplied drilled.

Note:

For applications which necessitate the blades to be installed vertically, BSB's Sales Office must be informed so that thrust bearings are fitted to eliminate blade friction.

Special Note:

BSB can manufacture to individual specifications and applications. Illustrated are standard variants only, with other variants to order.

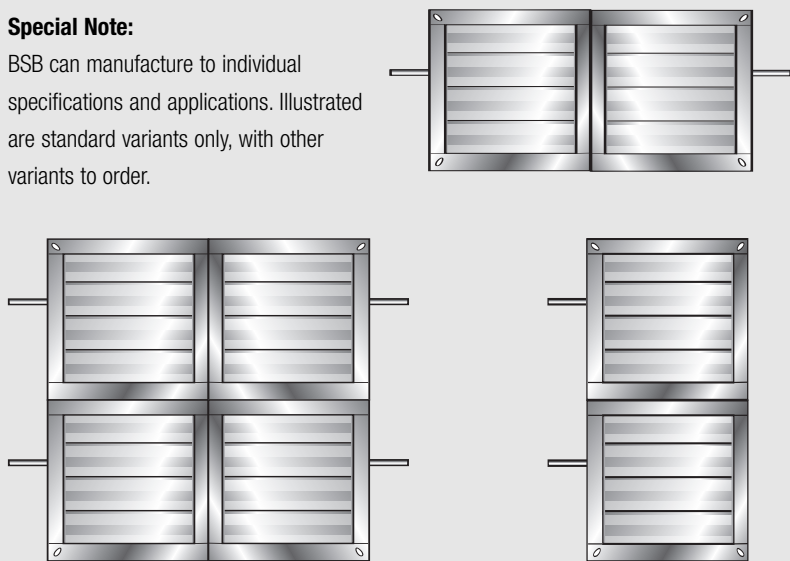

Option E Extended Spindle

For motorisation by others.

Supplied with 19mm spindle. 135mm in length.
12mm square spindle available to order.

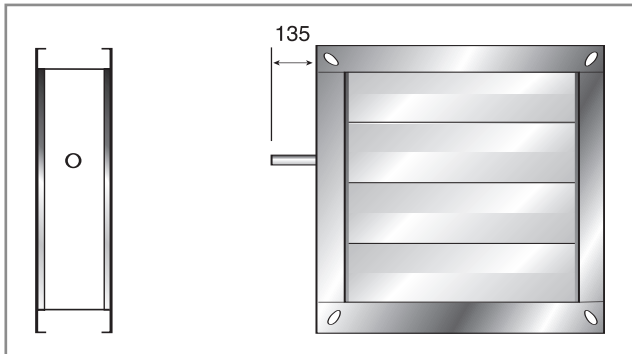

Option M Electric Motor

Can be supplied with the following control motors fitted:

- Open/Close Operation
- Spring Return Operation
- Or as specified

12mm square spindle available to order

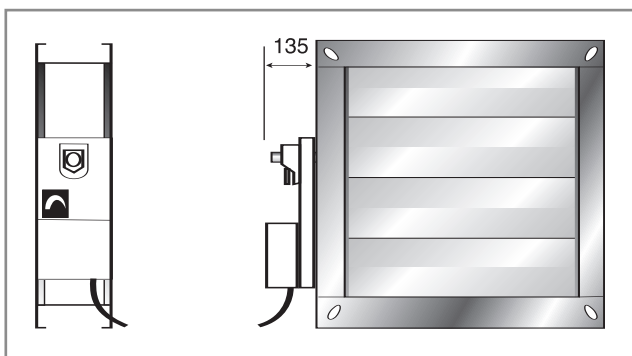

Option H Hand Control

BSB's unique hand lockable quadrant is supplied complete from the factory.

Option H Manual Quadrant Control is easily converted to Option E for motorisation by others without the need for specialist tools on site.

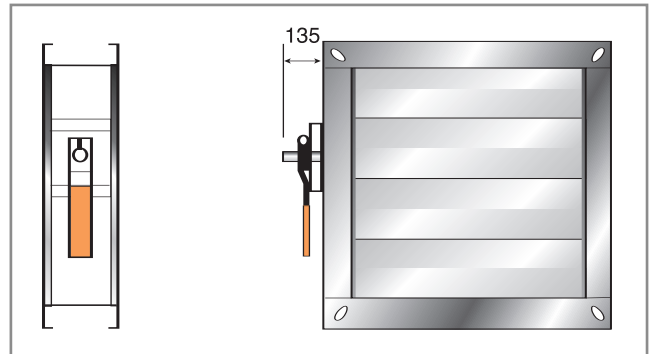

Option P Pneumatic Actuator

Operates between 20psi/1.4bar and 100psi/7bar. Supplied fitted to the damper complete with integral threaded airports to pressurise and vent the actuator. Accessories available.

A = 100mm or 150mm dependant on actuator model supplied.

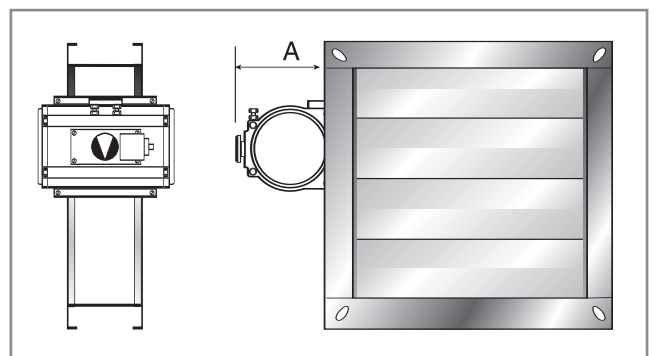

Thermal Housing

The thermal motor enclosure consists of an advanced phenolic composite resin. The enclosure uses a mould which has been specifically designed to encase Damper Actuators.

The thermal housing has been independently fire tested at 300°C by the Warrington Fire Research Establishment and results show that the surface temperature of the actuator inside the enclosure did not exceed 78°C during the 60-minute test.

The use of a thermal enclosure provides a tested and proven method to ensure operation of sensitive equipment when subjected to the extremities of fire.

Enclosure size: 395mm length - 174mm width and 140 depth

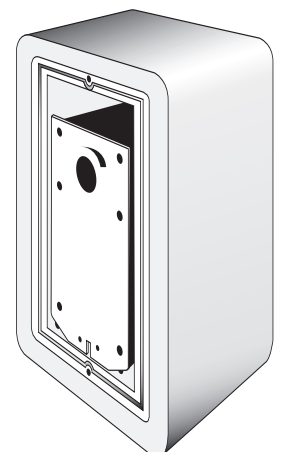

SC Series

ordering codes



Ordering Codes Example



SC Series Smoke Control Damper

Case

- F Flangefit
- S Spigotfit
- C Circular
- O Flat Oval

Blade Material

- G Galvanised Mild Steel
- S Stainless Steel (specify grade)

Options

- E Extended Spindle
- H Hand Control
- M Electric Motor
- P Pneumatic Motor
- T Thermal Housing

Air, Fire and Smoke Control

Air Balance Control



BD Series
Backdraught
Regulating Dampers



DD Series
Duct Regulating
Dampers



HD Series
Heavy Duty Regulating
Dampers



SB Series
Single Blade
Regulating Dampers



SF Series
Slimfit Regulating
Dampers

Fire and Smoke Control



FD Series
Fire Control



FSD Series
Fire and Smoke
Control



SC Series
Smoke Control



Control Systems
Electro Mechanical



Control Systems
Fully Addressable